

6. studenoga 2024.,
virtualno događanje



**Godišnja konferencija eTwinninga
„Dobrobit u školi – napredujemo zajedno”**

eTwinning well-being u svijetu struke

Ana Marketin-Sedlar, eTwinning
ambasadorica



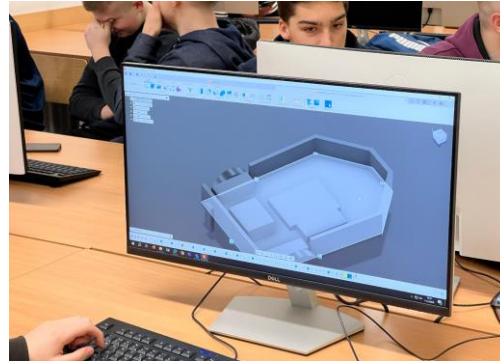

Podučavanje današnjice

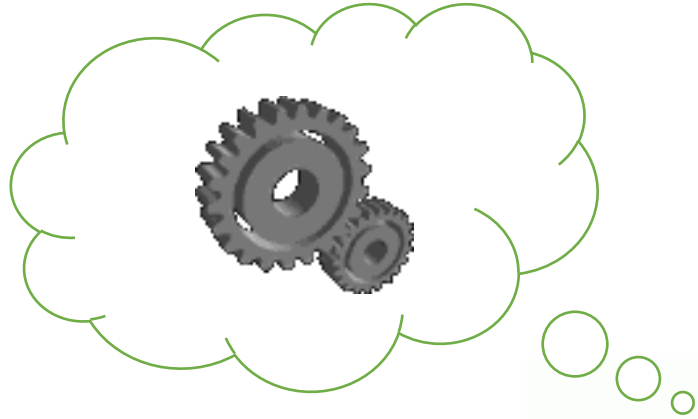

[Slido](#)





Flambiranje

Zidanje

Eksperimentiranje

Programiranje

Dizajniranje

Konstruiranje

Kuhanje



Snimanje

Planiranje

Dijagnosticiranje

Tokarenje

Šivanje

Crtanje

Pisanje

Sađenje

Ali....

- Tagiranje
 - Umrežavanje
 - Pretraživanje
 - Parafraziranje
 - Bookmarking
 - Bloging
 - Podcasting
 - Subscribing
 - Posting
 - Twittering
 - Komentiranje
 -
- Odgovornost
 - Radoznalost
 - Odlučnost
 - Tolerantnost
 - Prilagodljivost
 - Poštovanje
 - Samopouzdanje
 - Empatija
 - Optimizam
 - Poslovna inteligencija
 - Humor
 -

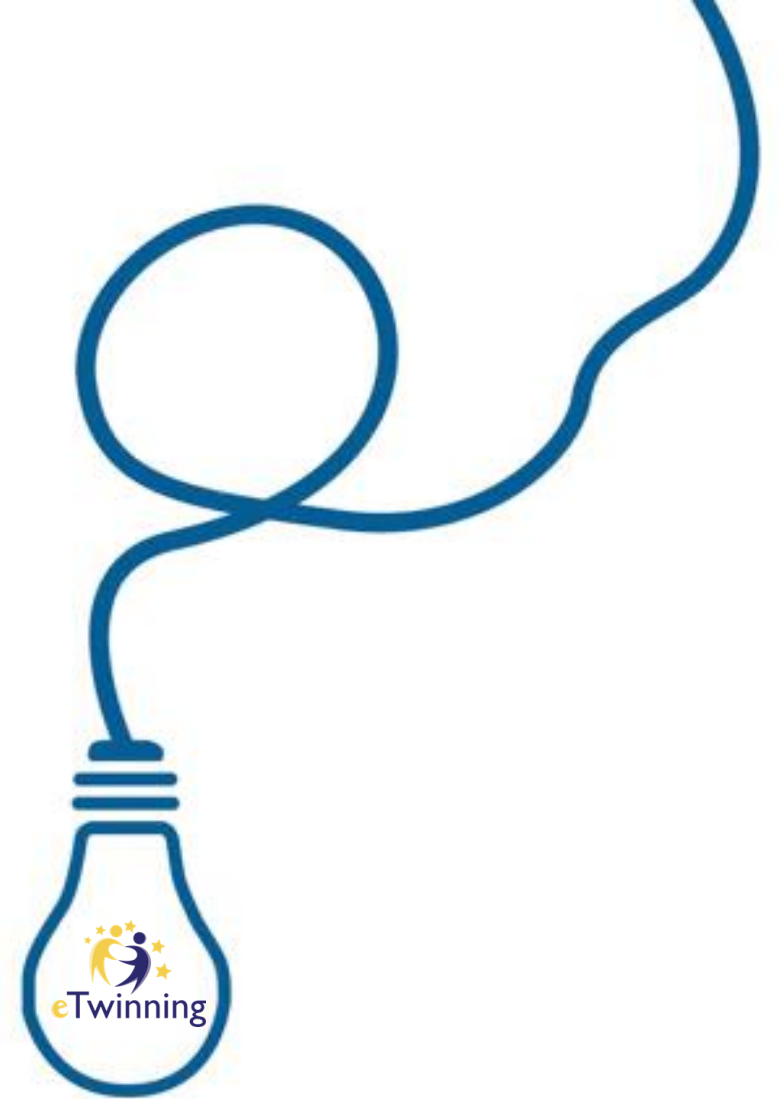

Organiziranje nastave struke uz planiranje podučavanja

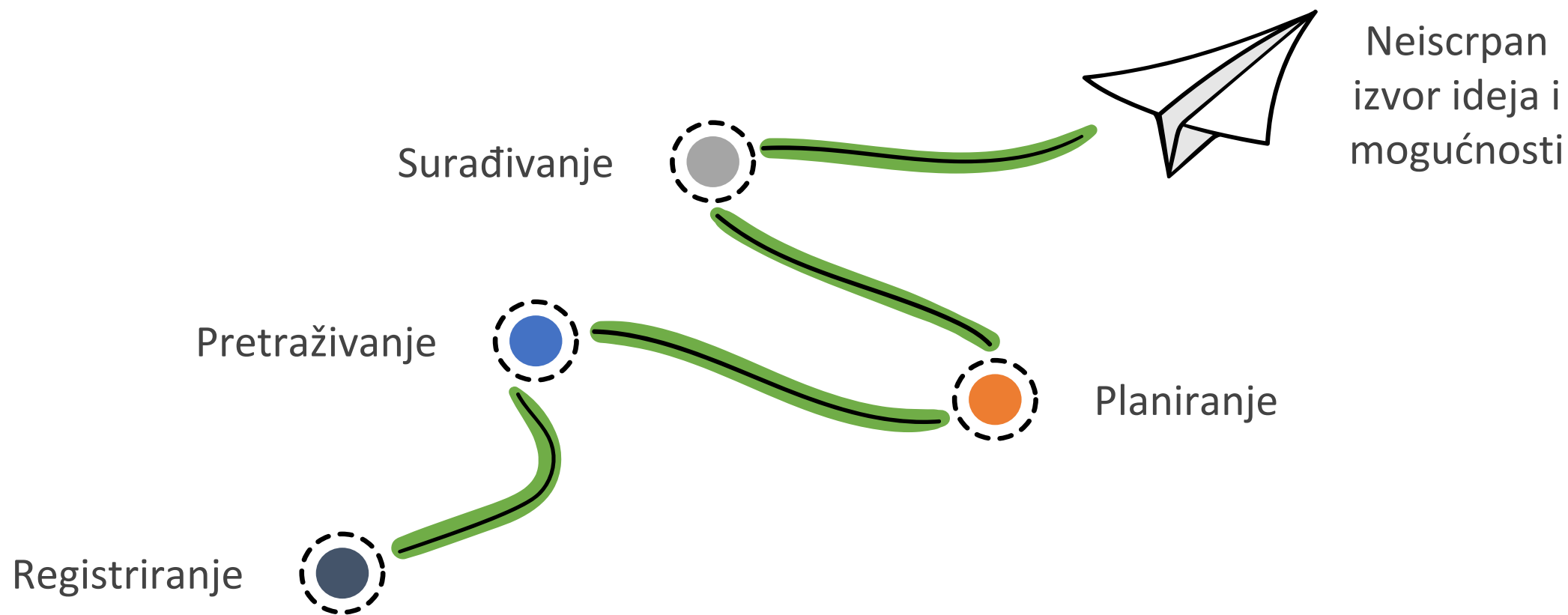

Kako planirati podučavanje u nastavi struke?

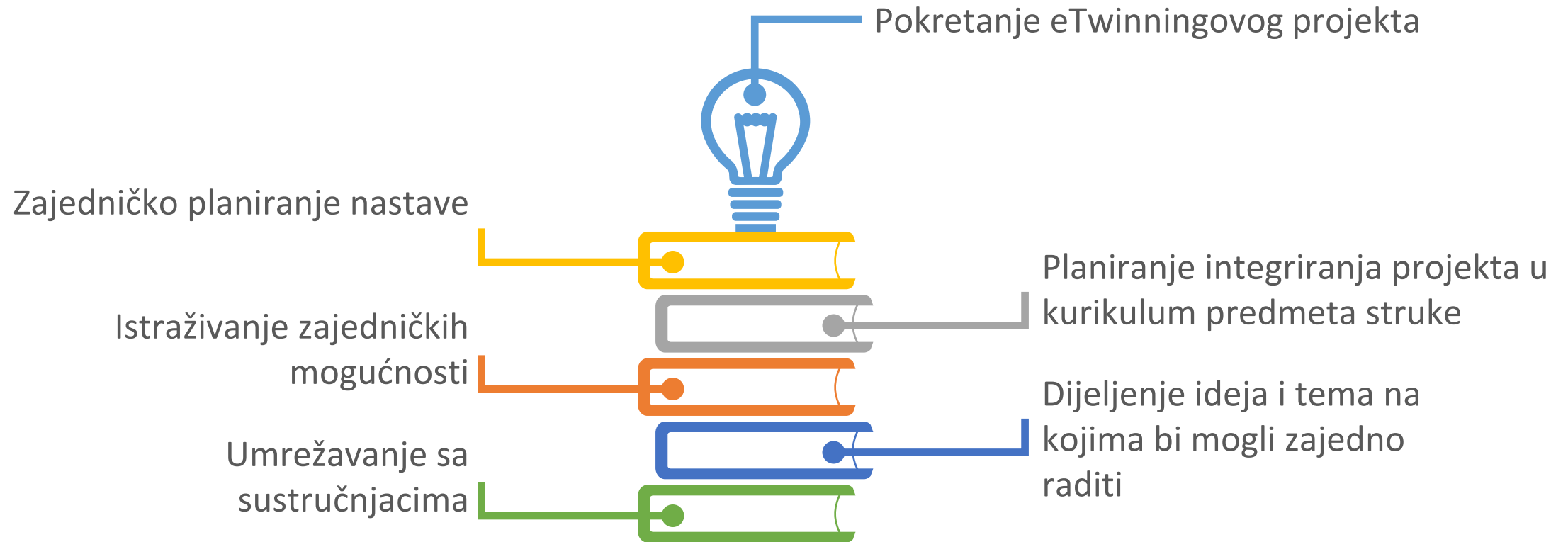

podučavanje samo na strukovni kurikulum ili?

breshna.io

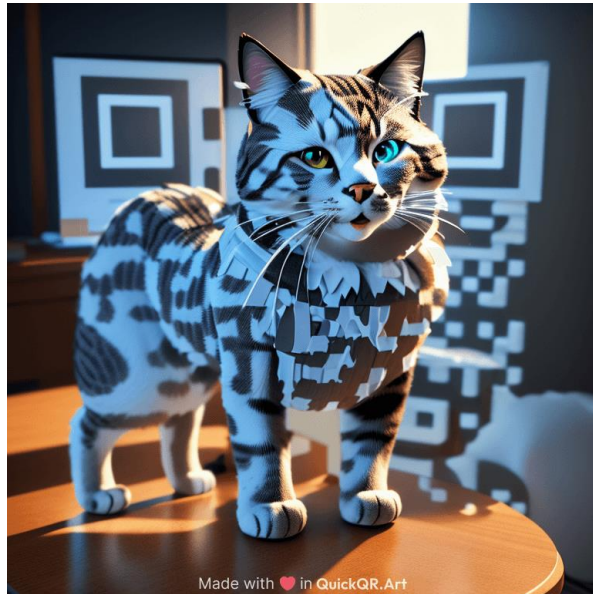

Utjecaj podučavanja na nastavu struke

STRUKOVNI KURIKULUM

- osmišljen kako bi učenicima pružio specifična znanja, vještine i kompetencije potrebne za određeno zanimanje ili struku, odnosno za tržište rada
- praktične vještine; teorijska znanja; radna praksa; suradnja s obrtnicima



SKRIVENI KURIKULUM

- odnosi se na vrijednosti i norme koje učenici usvajaju kroz školsku okolinu i interakcije, a koje nisu dio formalnog nastavnog plana i programa
- disciplina i pravila; učiteljski odnosi; školska kultura

Zašto wellbeing kroz ?

- eTwinning u 2024. godini istražuje temu dobrobiti u školi prateći akademski uspjeh učenika i općenito zadovoljstvo učenika i odgojno-obrazovnih djelatnika
- Temom wellbeing eTwinning naglašava važnost stvaranja sigurnog i uključivog okruženja za učenike i odgojno-obrazovne djelatnike
- Dobrobit u školi povezana je s pozitivnim odnosima i boljom pripremom za život izvan škole
- [Putevi do školskog uspjeha](#)
- [eTwinningova godišnja tema za 2024.: Dobrobit u školi – zajedničko napredovanje](#)



Wellbeing +

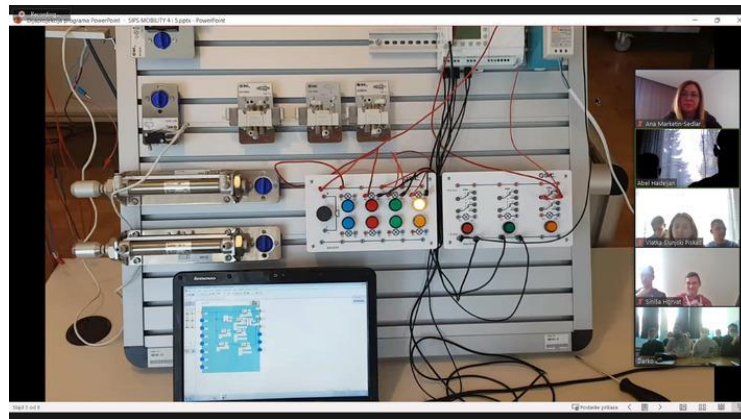

Wellbeing +



Wellbeing kao dio školske svakodnevice

<https://wheeloflife.noomii.com/>



Primjeri



nastave u strukovnim zanimanjima

Pink Shirt Day



Inventors who changed
technical world



S.T.O.P.



Quality 4 us
Šarene klupe budućnosti

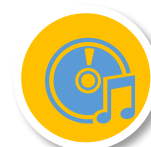

Let's love the
Mediterranean sea
Keep calm and go solar

Primjeri nastave u strukovnim zanimanjima

6
šešira

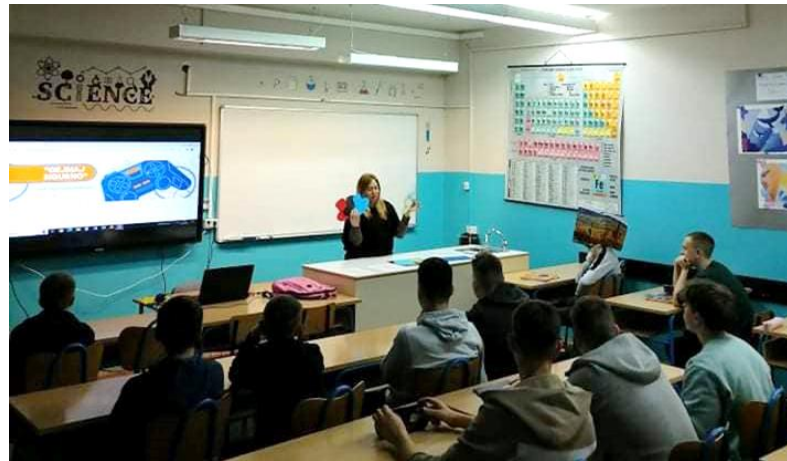

Scenarij poučavanja

Primjeri nastave u strukovnim zanimanjima



Primjeri nastave u strukovnim zanimanjima

5 Es

- Engage,
- Explore,
- Explain,
- Elaborate,
- Evaluate.



e-knjiga

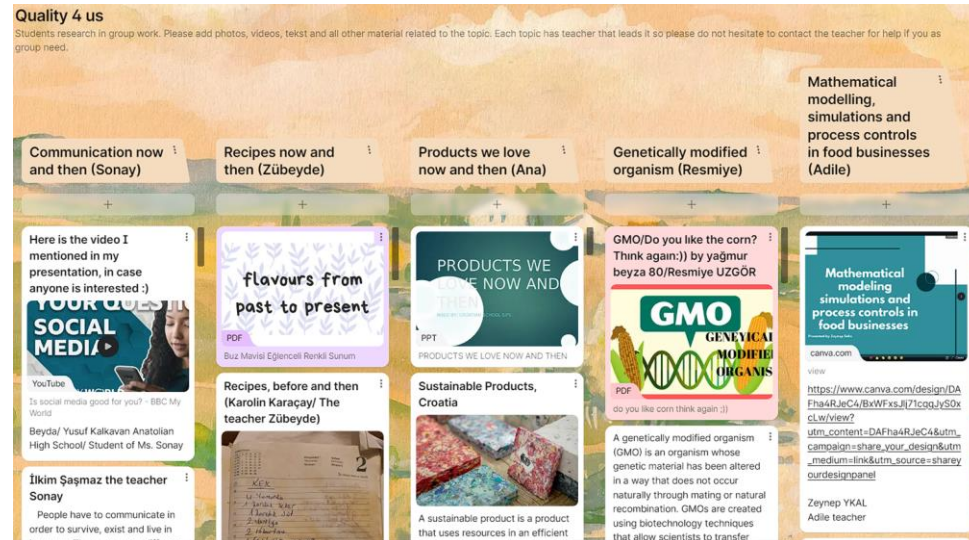

LAŽNE VIJESTI VEZANE ZA KVALITETU MATERIJALA I TEHNOLOGIJU OBRADE



Primjeri nastave u strukovnim zanimanjima

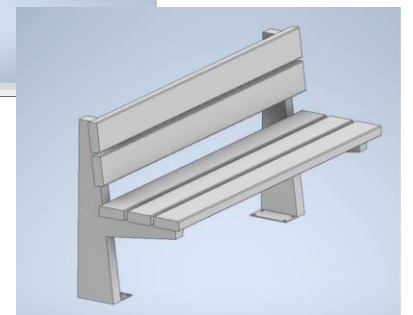
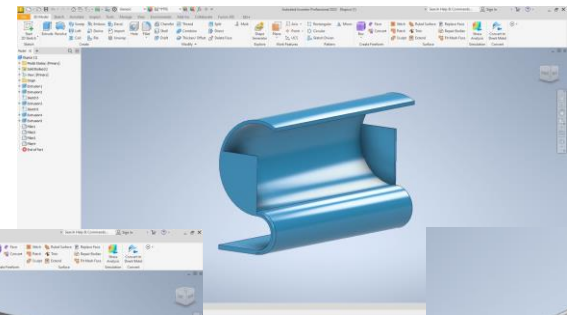
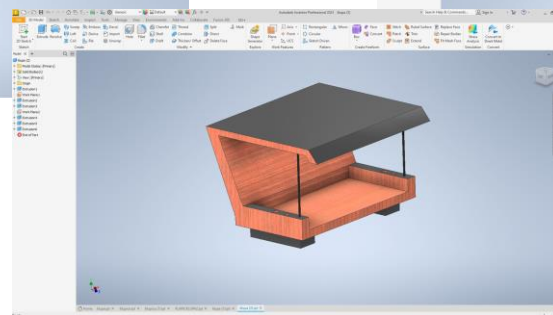
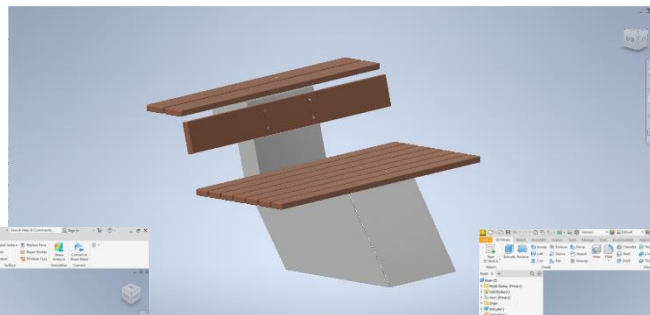
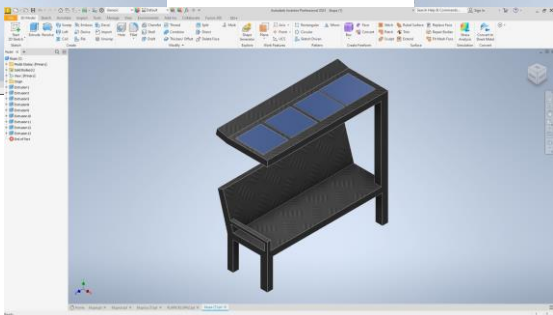
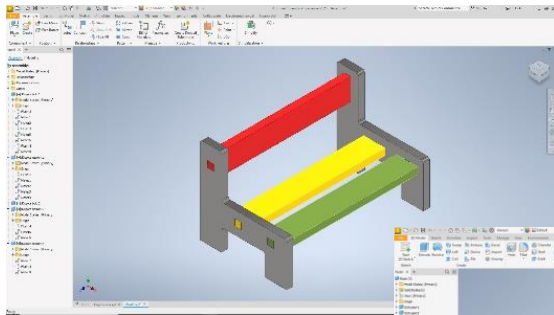

Primjeri nastave u strukovnim zanimanjima

4C

- Critical thinking,
- Creativity,
- Collaboration,
- Communication.

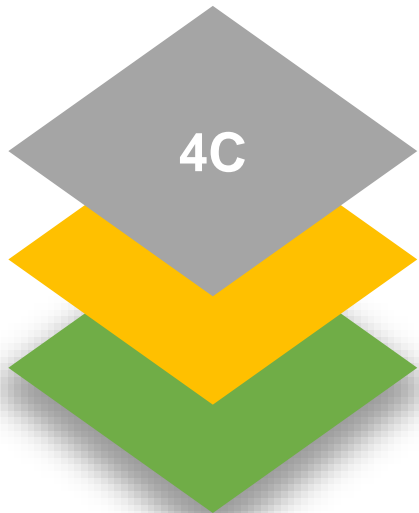
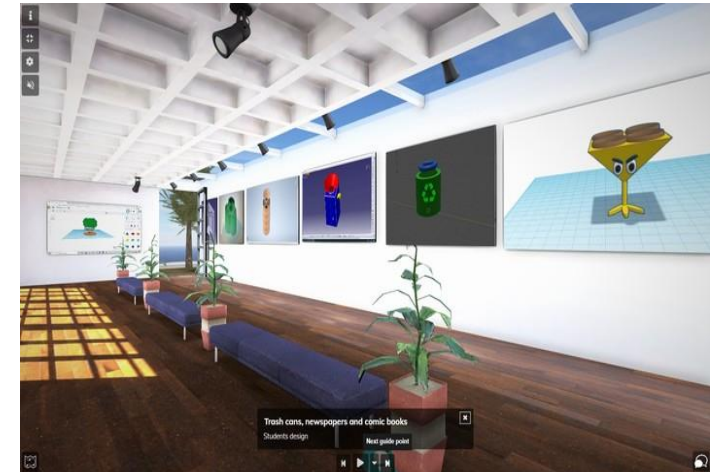
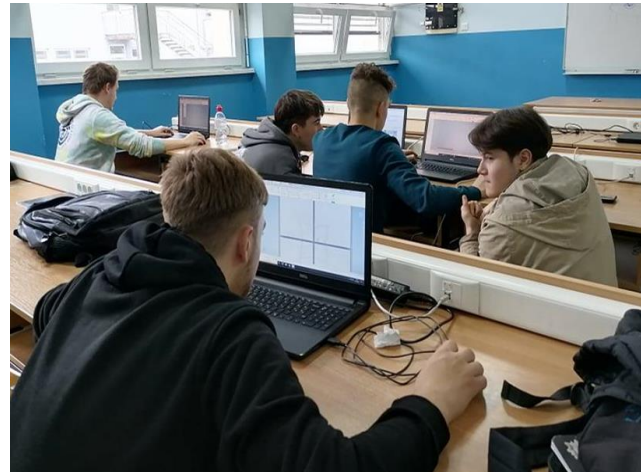

[e-muzej](#)

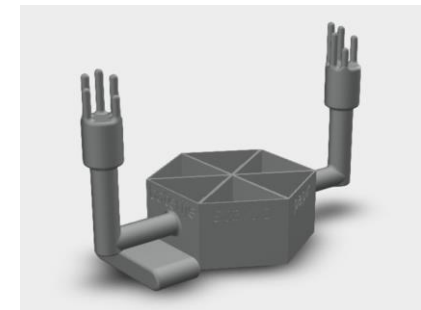
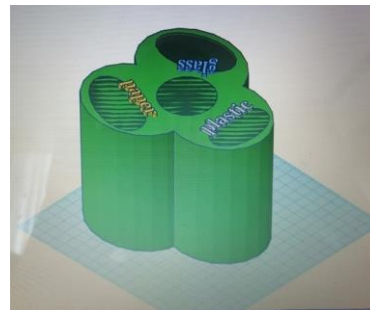

Primjeri nastave u strukovnim zanimanjima



Primjeri nastave u strukovnim zanimanjima



[madmagz.com](https://www.madmagz.com)

[canva.com](https://www.canva.com)

[genially.com](https://www.genially.com)

[postermywall.com](https://www.postermywall.com)



[canva.com](https://www.canva.com)

[learningapps.org](https://www.learningapps.org)

[learningapps.org](https://www.learningapps.org)

[fodey.com](https://www.fodey.com)



[e-časopis](https://www.e-časopis.com)

**Before you post...
THINK!**

- T** is it true?
- H** is it harmful?
- I** is it illegal?
- N** is it necessary?
- K** is it kind?



What is the primary way dolphins communicate with each other?

- A** Dancing
- B** Flapping the fins
- C** Singing
- D** Clicking and whistling

Primjeri nastave u strukovnim zanimanjima

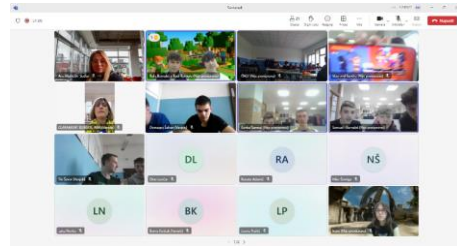

Primjeri nastave u strukovnim zanimanjima



[fodey.com](https://www.fodey.com)



Primjeri nastave u strukovnim zanimanjima

armeasure.com

[AR Ruler App](#)

[imagine.art](https://www.imagine.art)

[shutterstock.com/](https://www.shutterstock.com/)

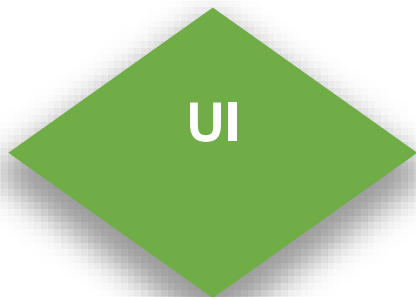

- INTERNET AS A GLOBAL MEETING PLACE ^
- 3.1 Autor rights
- 3.2 Internet safety
- 3.3 Netiquette
- 3.4 Common presentation about safe use of Internet
- 4 OUR MEETINGS ^
- 4.1 Teachers meetings
- 4.2 Students meetings
- 5 QUESTIONNAIRES ABOUT SIGNS ^
- 5.1 First questionnaire
- 6 SIGNS WITH WHICH WE ARE SURROUNDED ^
- 6.1 Let's explore the signs that surround us
- 6.2 Traffic signs - first group presentation
- 6.3 Signs on vehicles - second group presentation
- 6.4 Signs on buildings - third group presentation
- 6.5 Signs on public areas - fourth group presentation
- 6.6 Cases about signs that

https://www.canva.com/design/DAGQzxHupNY/Q4OdbJvmbLT9Aedn0yFXnQ/watch?utm_content=DAGQzxHupNY&utm_campaign=designshare&utm_medium=link&utm_source=editor

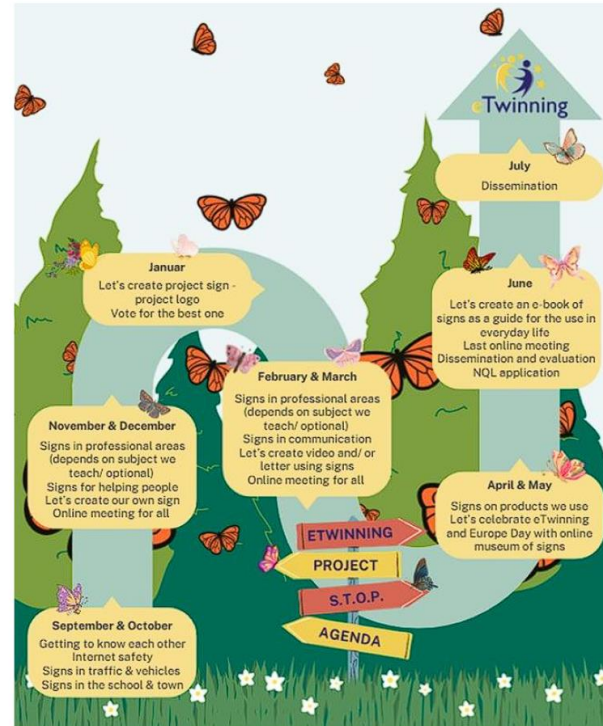

Page options

Every day we are passing by so many different signs. Which of them do you pay most attention to? Which of them you haven't pay attention to?

Let's start with fun task.

Take a good look at the school, the school yard, the city and the traffic around you. Take photos of signs you didn't notice before and put them on the Twinboard. Explain where you saw the sign and why haven't you pay attention to it before.

Photos of signs Add item



Child transport
This sign represents transportation of children to school most of the time.



Usual sign
Sign of track for stopping and parking.



Footpath
This is sign that we usually see.

Wellbeing kao dio školske svakodnevice

<https://www.calm.com/blog/5-4-3-2-1-a-simple-exercise-to-calm-the-mind>

Imenujte 5 stvari
koje vidite

Imenujte 4 zvuka
koja čujete

Imenujte 3 osjećaja
koja osjećate

Imenujte 2 mirisa
koja osjećate

Imenujte 1 okus koji
osjećate



Evaluacija radionice naziva eTwinning well-being u svijetu struke

<https://bit.ly/etwinningovaevaluacija>



Hvala na pažnji!

ana.marketin-sedlar@skole.hr

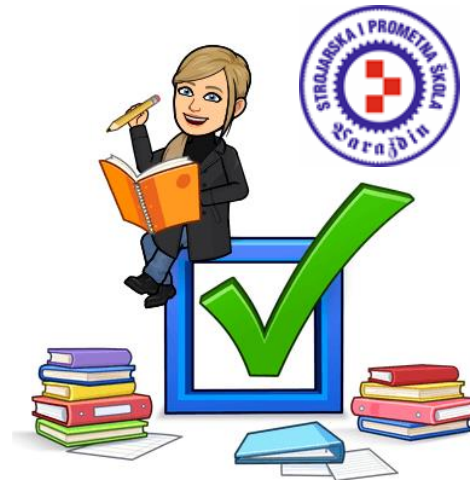

Ova je prezentacija ostvarena uz financijsku potporu Europske komisije. Ona izražava isključivo stajališta svojih autora i Komisija se ne može smatrati odgovornom pri uporabi informacija koje se u njoj nalaze.